

DISCOVER TODAY'S SOLUTIONS FOR TOMORROW'S
NANO CHARACTERIZATION CHALLENGES

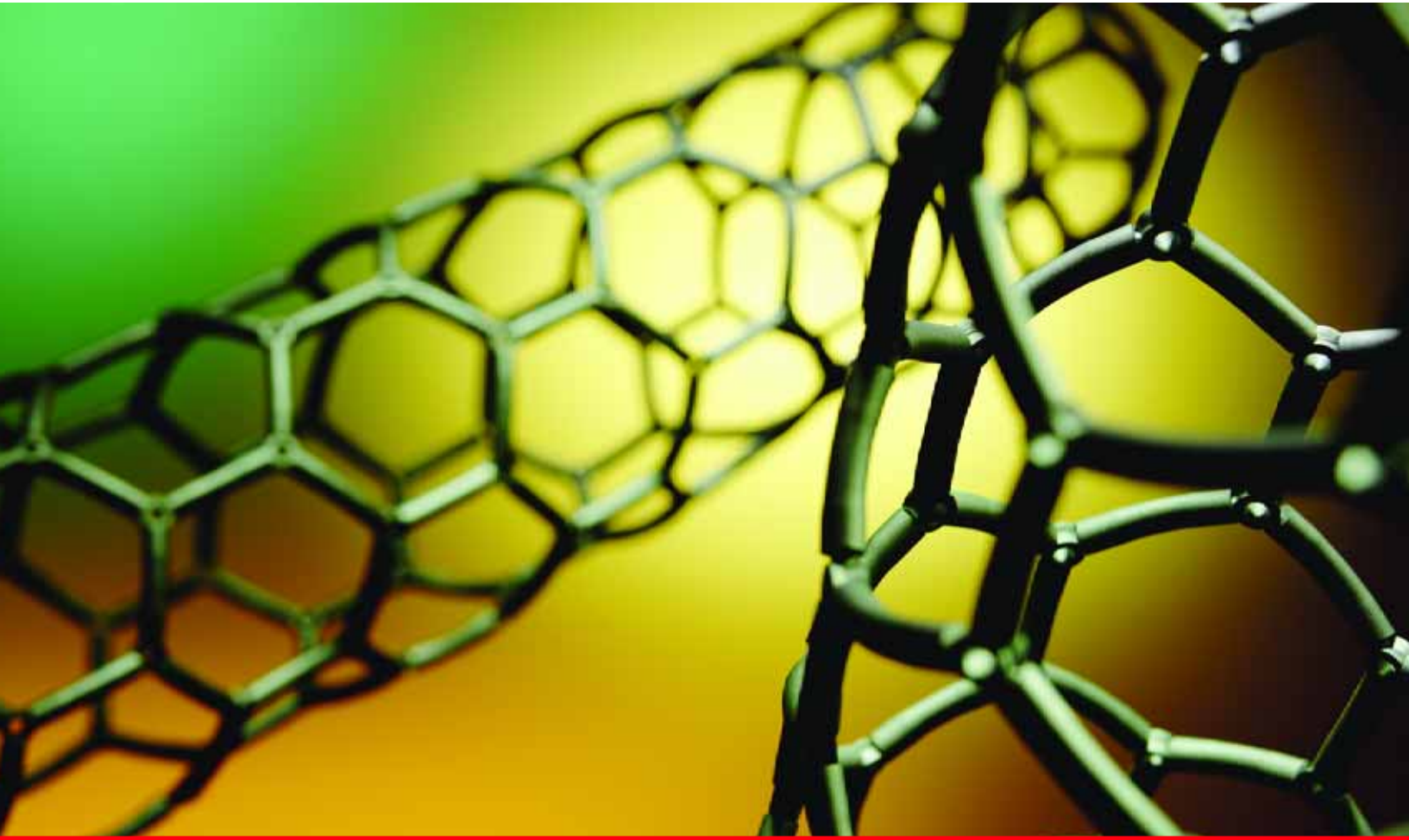

KEITHLEY

A GREATER MEASURE OF CONFIDENCE

The leader in nanotechnology measurement solutions



Keithley is **helping advance the state of the art** in a growing list of nanotechnology applications—yours may be one of them. **Six decades of experience in designing ultra-sensitive measurement tools** allow us to provide university, corporate, and government labs around the world with solutions for investigating new material and device properties. Just as important, these solutions are designed for intuitive operation, so you can focus on your research, not on learning how to use the hardware.

We partner with organizations like the Institute of Electrical and Electronics Engineers (**IEEE**), leading Nanotechnology Centers of Excellence, Keithley **customers**, and other leading nanotechnology measurement tool vendors to create more complete solutions. The **insight into emerging needs** these working partnerships provide helps us deliver new capabilities faster.

What kinds of measurement challenges do your nanotechnology applications present?

Nanotechnology research is advancing so rapidly that many scientists find that their existing measurement tools simply lack the sensitivity or resolution needed to characterize low level signals effectively. Others are scrambling to keep up with the rapid changes in measurement requirements that new discoveries create. No matter which challenge you're facing, Keithley can help.

Need wider ranges for your nanoscale materials research?

Understanding how building block materials like nanocrystals, nanotubes, nanowires, and nanofibers will perform in tomorrow's electronics demands instrumentation that can characterize resistance and conductivity over wide ranges. Keithley combines all the necessary sourcing and measurement tools into a variety of easy-to-use test solutions. Many are designed for easy integration with other instruments to extend system ranges and capabilities even further.

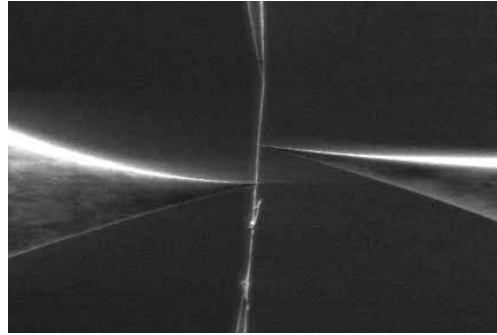

A four-wire connection to a carbon nanotube. Image reproduced here courtesy of Zyvex Corporation.

Experimental nanostructures can't take the heat?

During device development, structures like single electron transistors (SETs), sensors, and other experimental devices often display unique properties. Characterizing these properties without damaging one-of-a-kind structures requires systems that provide tight control over sourcing to prevent device self-heating. Keithley instrumentation combines this tight control with exceptional measurement speed and sensitivity in flexible, modular architectures that make it easy to adapt to changing test requirements.

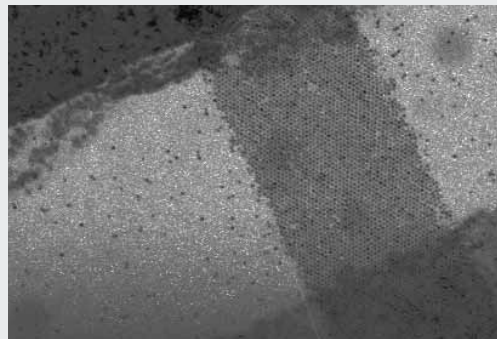

A device formed by an array of gold nanoparticles. Photo courtesy of K. Elteto and X.M. Lin, the University of Chicago.

Preparing to make the leap into production?

Our growing line of I-V characterization tools can help you make the jump from the lab into commercial production sooner. Their wide sourcing and measurement ranges allow you to study how next-generation nanoelectronics like carbon nanotube field-effect transistors (CNTFETs), SETs, and other exotic devices will perform under a variety of conditions.

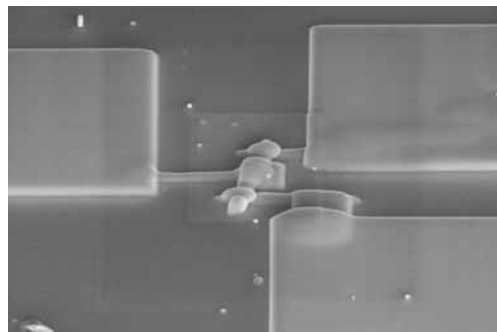

TiO₂ nanotube image courtesy of Dr. Jiyoung Kim, University of Texas at Dallas

Visit www.keithley.com/nano to learn more about why we're leading the industry in the development of measurement solutions for nanotechnology research and production test.

Which Keithley nanotechnology solution is best for your sourcing or measurement application?

Keithley instrumentation is being used in a growing list of nanotechnology research and production test settings. The applications shown here are only a sampling of the nanotechnology test and measurement tasks for which our instruments and systems are suitable. If your tests require sourcing or measuring low level signals, Keithley instrumentation can help you perform them more accurately and cost-effectively.

Want seamless control over current pulse sourcing and measurement?

When linked together, the **Model 6221 AC+DC Current Source** and **Model 2182A Nanovoltmeter** are designed to operate like a single instrument to make high speed pulse mode measurements. **Learn more on pages 9, 13, and 14.**

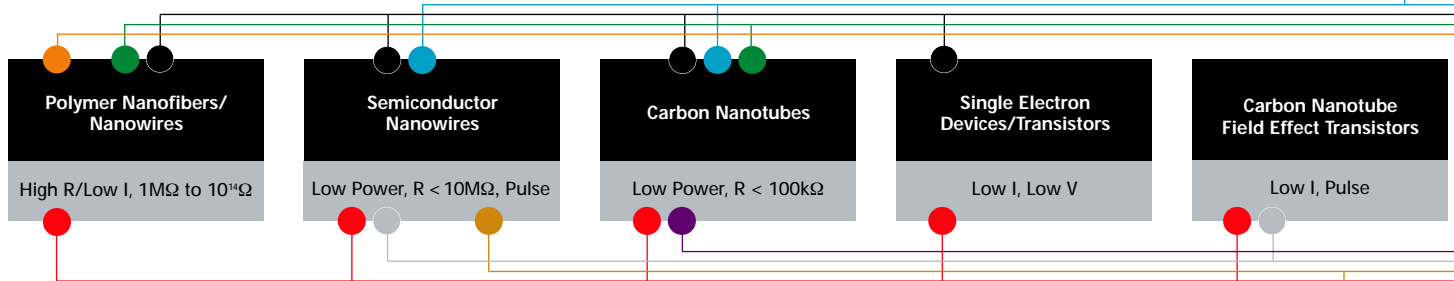

Want multiple channels of sourcing and measurement?

The fully integrated **Model 4200 Semiconductor Characterization System** brings together up to eight channels in one easy-to-operate package. It's used in many phases of nano research, development, characterization, and production. **Learn more on pages 6, 7, 10, and 11.**



Need tighter control over your pulses?

Our newest pulse generation solutions, **Series 3400 Pulse/Pattern Generators**, can output voltage pulses with widths as short as 3ns, with independently adjustable rise and fall times as short as 2ns. **Learn more on pages 9 and 19.**



The Model 4200-SCS conforms to and supports the new IEEE Standard P1650™-2005: "IEEE Standard Test Methods for Measurement of Electrical Properties of Carbon Nanotubes," the world's first electrical measurement standard for these devices.

Studying highly resistive nanowires?

The **Model 6430 Sub-Femtoamp Remote SourceMeter**[®] instrument's low noise and drift performance make it ideal. It measures currents with 400aA (400×10^{-18} A) sensitivity. **Learn more on page 12.**



Trying to characterize high resistance nanomaterials?

The **Model 6517A Electrometer/High Resistance Meter's** built-in 1kV source, 200T Ω input resistance, and low current sensitivity make it an ideal solution. **Learn more on page 15.**



Want low current measurements without the high price tag?

With $<200\mu\text{V}$ burden voltage, the cost-effective **Model 6485 Picoammeter** ensures accurate low current measurements, even in circuits with very low source voltages. The **Model 6487 Picoammeter/Voltage Source** adds a 500V bias source for high resistance and resistivity measurements. **Learn more on page 16.**



Nanobatteries

Low I, Low Power

Nanophotonics

Low I, Pulse

Synthesized Molecular Electronics/Wires

Low I, Low Power

Nanosensors & Arrays

Low I, Low V

Thermal Transport

Low I, Low Power, Pulse

Troubled by overheating problems?

The **Model 4200-PIV Option** for the Model 4200-SCS combines a pulse generator, an oscilloscope, a specialized interconnect, and powerful software to control pulse I-V testing of devices with self-heating issues. **Learn more on page 8.**



Testing lots of devices?

Series 2600 System SourceMeter instruments let you make precision DC, pulse, and low frequency AC source-measure tests quickly, easily, and economically. They offer virtually unlimited flexibility to scale the system's channel count up or down to match changing application needs. **Learn more on page 17.**



Looking for just a single channel?

Each **Series 2400 SourceMeter instrument** is a complete, single-channel DC parametric tester. Choose from a variety of ranges and functions to suit specific application needs. The Model 2430 can be programmed to produce individual pulses or pulse trains up to 5ms wide. **Learn more on page 18.**

Need really high current pulses?

The **Model 2520 Pulsed LIV Test System** can source pulses up to 5A with programmable pulse on times from 500ns to 5ms. A remote test head minimizes cable effects and maximizes the signal-to-noise ratio for greater pulse measurement accuracy. **Learn more on page 19.**



To discuss how we can work with you to configure a solution for a specific nanotechnology application, contact Keithley's Applications Engineering department and ask to speak with one of our nano measurements experts. In the U.S., call us toll free at 1-888-KEITHLEY (534-8453). Or contact one of the sales offices listed on the back cover for guidance.

Model 4200-SCS: Tackle both today's ultra-precise measurements and tomorrow's evolving nano challenges

Keithley originally developed the Model 4200 Semiconductor Characterization System for the semiconductor industry, but nanotechnology researchers and production test experts soon discovered its effectiveness for developing and studying nanoscale materials and devices. Today, this powerful characterization system is the industry-standard tool used in nanotechnology labs around the world in applications ranging from materials research and nanostructure development to I-V characterization of nanoelectronic devices. The system's popularity is due in part to our commitment to enhancing its hardware and software to meet emerging test needs. Our ongoing commitment to the Model 4200-SCS ensures we'll continue to provide you with a cost-effective system upgrade path to new measurement capabilities.

- Start testing productively right out of the box. The Model 4200-SCS's intuitive Windows®-based interface minimizes the system-specific training needed and allows even novice users to begin taking data almost immediately. Whether your background is in biology, chemistry, physics, semiconductor engineering, or some other discipline, the Model 4200-SCS delivers the test results you need faster.
- Organize your tests with the built-in Project Navigator, which automates test sequencing and often eliminates the need to write code.
- Customize and modify your test parameters easily using the system's point-and-click interface. Less time spent on test development allows more time to focus on your research.
- Take advantage of the powerful scripting language to create more advanced tests as new testing needs arise.



“The Model 4200-SCS makes it simple to obtain and analyze data, so we can learn the electronic characteristics of nanodevices almost immediately. It’s a very user-friendly design – it’s easy to set up and operate with no training needed.”

- Dr. Iwao Ohdomari, Professor of Science & Engineering, Waseda University, Japan

Learn more by downloading *“I-V Measurements of Nanoscale Wires and Tubes with the Model 4200-SCS and Zyvex S100 Nanomanipulator”* at www.keithley.com/nano.

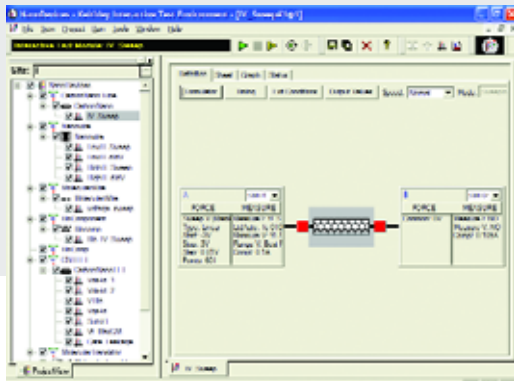

Characterize the seven most common nanodevice structures quickly and easily using Keithley's free Nanotechnology Toolkit, developed specifically for use with the Model 4200-SCS. Together, the system and the toolkit help you focus on your research by slashing the time needed to develop new applications or to refine them as new test requirements emerge.



Use a Model 6221 AC+DC Current Source and a Model 2182A Nanovoltmeter with a test system based on the Model 4200-SCS to extend its low power measurement range to $< 1\text{fW}$ and its low resistance measurement range to 10Ω .

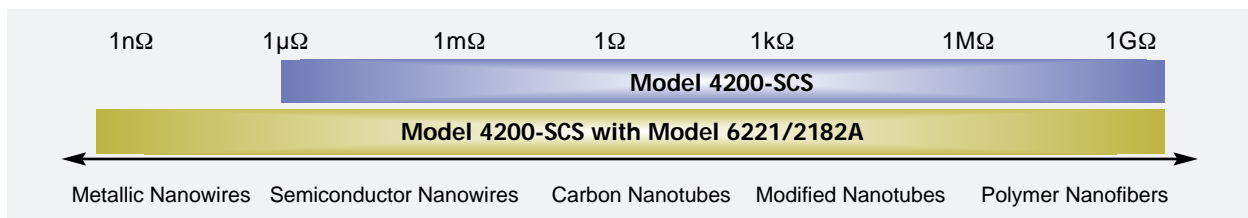

- Probe nanoscale materials, experimental structures, and scaled CMOS devices with superior precision with Zyvex's S100 Nanomanipulator and the Model 4200-SCS. Ask us about other compatible testing, fixturing, and probing systems available.
- Install up to four positioners in the S100 to grasp, move, position, and test samples in scanning electron microscopes (SEMs) and focused ion beam systems.
- Probe even the smallest devices with the S100's 5nm positioner resolution and support for probes less than 20nm in diameter.

Zyvex S100 Nanomanipulator

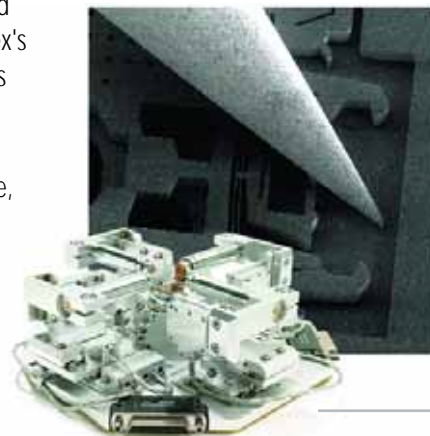

Keep your finger on the pulse of new nano testing technologies

New materials, miniscule device dimensions, and higher operating speeds have all combined to make characterizing nanostructures more challenging than ever. Traditional DC I-V techniques can lead to joule heating of the device, affecting device response and masking the phenomenon of interest, or even destroying priceless experimental devices. By minimizing the amount of energy pumped into a device, Keithley's growing line of pulse testing solutions offers valuable alternatives to DC characterization methods.

Save time and money with the Model 4200-PIV

Now, incorporating a pulse I-V characterization system into your nano lab is no longer a "do-it-yourself" project or a major strain on the capital equipment budget. Our new 4200-PIV bundle is a comprehensive package of hardware and software (including patent pending cable and load-line compensation utilities), designed to integrate seamlessly with the Model 4200-SCS workstation. It includes everything you need to implement a turnkey system for pulsed I-V testing of nanostructures:

- Integrated dual-channel pulse generator
- Dual-channel digital oscilloscope
- Control software
- Interconnect fixture that minimizes the signal reflections common to pulse I-V testing
- All required connectors and cables
- Pulse I-V sample project created for isothermal testing

Control the amount of energy transmitted to the device precisely with independently controllable pulse rise and fall times. Source pulses as short as 40ns.

View results in the way that's best suited to your application—V or I vs. time, DC bias current vs. pulse voltage response, etc. DC and pulse operation are fully integrated.

Compare results from DC measurements and pulse response measurements easily in the same window.

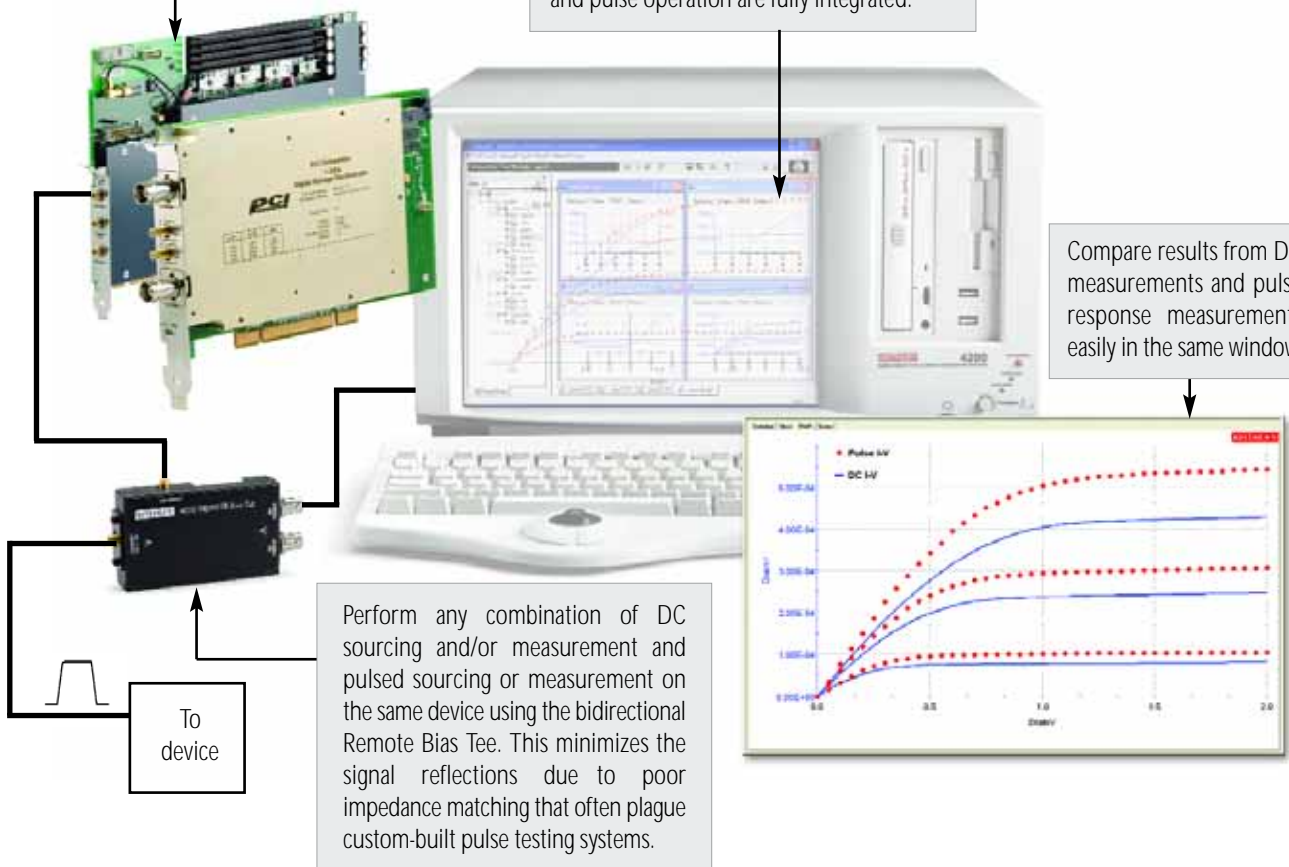

Model 6221/2182A AC+DC Current Source/ Nanovoltmeter Combination

These instruments are natural measurement partners for applications such as characterizing nanotubes and nanowires. The Model 6221 current source can produce current pulses as short as $5\mu\text{s}$ when used as a stand-alone pulse source or as short as $50\mu\text{s}$ when used with the Model 2182A. This high speed pulsing capability reduces the power dissipated in the device, minimizing device self-heating and preventing device damage. The Model 2182A nanovoltmeter combines low noise, thermoelectric EMF cancellation, fast measurement rates, and 2ppm accuracy. When linked together and operated in pulse mode, the current source configures the nanovoltmeter over the RS-232 interface, controls it through the Trigger Link interface, and then automatically retrieves the data for calculation.



Series 3400 Pulse/Pattern Generators



Voltage pulsing can produce much narrower pulse widths than current pulsing, so it's often used in experiments such as thermal transport, in which the timeframe of interest is shorter than a few hundred nanoseconds. High amplitude accuracy and programmable rise and fall times are necessary to control the amount of energy delivered to a nanodevice. Series 3400 Pulse/Pattern Generators can simplify simulating serial data patterns for use in testing devices to characterize their performance when operated under sub-optimal conditions like low supply voltage, propagation delay, and slow edge slew.

Both the single-channel Model 3401 and the dual-channel Model 3402 can output voltage pulses with pulse widths as short as 3ns, with independently adjustable rise and fall times. The Model 3402's dual outputs allow tight synchronization of pulses to multi-pin devices. For applications that require generating multi-step pulses, the Series 3400 makes it easy to combine multiple channels, with fully independent control over each channel. Trigger outputs simplify synchronizing the operation of multiple units.



- Intuitive, point-and-click Windows®-based environment
- Unique Remote PreAmps extend the resolution of SMUs to 0.1fA
- New pulse and pulse I-V capabilities
- New scope card provides integrated scope and pulse measure functionality
- Self-contained PC provides fast test setup, powerful data analysis, graphing and printing, and on-board mass storage of test results
- Unique browser-style Project Navigator organizes tests by device type, allows access to multiple tests, and provides test sequencing and looping control
- Built-in stress/measure, looping, and data analysis for point-and-click reliability testing, including five JEDEC-compliant sample tests

Complete pulse and DC solution

Model 4200-SCS Semiconductor Characterization System

The easy-to-use Model 4200-SCS Semiconductor Characterization System performs lab-grade DC and pulse device characterization, real-time plotting, and analysis with high precision and sub-femtoamp resolution. It offers the most advanced capabilities available in a fully integrated characterization system, including a complete, embedded PC with Windows operating system and mass storage. Its self-documenting, point-and-click interface speeds and simplifies the process of taking data, so users can begin analyzing their results sooner. The powerful test library management tools included allow standardizing test methods and extractions to ensure consistent test results. The 4200-SCS offers tremendous flexibility, with hardware options that include four different switch matrix configurations, a variety of LCR meters, and pulse generators.

The 4200-SCS is modular and configurable. The system supports up to eight Source-Measure Units, including up to four high power SMUs with 1A/20W capability. An optional Remote PreAmp, the 4200-PA, extends the system's measurement resolution from 100fA to 0.1fA by effectively adding five current ranges to either SMU model. The PreAmp module is fully integrated with the system; to the user, the SMU simply appears to have additional measurement resolution available.

The Model 4200-SCS conforms to and supports the new IEEE Standard P1650™-2005: "IEEE Standard Test Methods for Measurement of Electrical Properties of Carbon Nanotubes."

Model 4200-SCS Semiconductor Characterization System

New Options

Our new hardware options integrate directly into the Model 4200-SCS chassis. They can be purchased as an upgrade to existing systems (KTEI version 6.0 required) or as an option for new systems.

Pulse I-V Package: The optional Pulse I-V package provides dual-channel pulse generation and measurement. Pulsed I-V testing offers a new approach to characterization testing. Its high speed pulses allow you to characterize materials and devices in nano applications.

Dual-Channel Pulse Generator: The optional integrated dual-channel pulse generator adds pulsing to the Model 4200-SCS's DC source and measure

capabilities. It supports voltage pulses as short as 20ns in high speed mode or up to +20V (into 50 Ω) in high voltage mode. With two pulse generators on one card, you have the flexibility to apply pulses to two points on a device under test, such as the gate and the drain, simultaneously.

Dual-Channel Digital Oscilloscope: The optional dual-channel digital oscilloscope integrates more than the performance of a bench-top oscilloscope into your 4200-SCS. It also supports time-domain measurements of pulse waveforms and monitors the reactions of devices under test to those pulses. Some of the features of this oscilloscope include: a broad selection of acquisition modes, triggers, measurements, calculations, and up to four reference waveforms.

Nanotechnology Toolkit for the Model 4200-SCS

Our Nanotechnology Toolkit makes characterizing nanoscale materials and devices simpler and faster than ever before. With 16 Interactive Test Modules (ITMs) for characterizing the seven most common nanodevice structures, the Toolkit brings together the capabilities you need to create powerful nanotech R&D software applications. Together, the Model 4200-SCS and the Nanotech Toolkit can help you to focus on your research by slashing the time needed to develop new applications or to refine them as new test requirements emerge.

Supported nanodevices and their associated Interactive Test Modules:

- Carbon Nanotube
 - I-V characteristics
- BioComponent
 - I-V characteristics
- Carbon Nanotube FET
 - +Drain Voltage vs. Drain Current
 - -Drain Voltage vs. Drain Current
 - Linear Threshold Voltage Sweep
 - Gate Voltage vs. Drain Current
 - Sub-Threshold Voltage Sweep
 - Threshold Voltage Max GM Sweep
 - Gate Leakage vs. Voltage Sweep
- Nanowire
 - Low Resistance Nanowire Sweep
 - Low Resistance Nanowire Differential Conductance Sweep
 - High Resistance Nanowire Sweep
 - High Resistance Nanowire Differential Conductance Sweep
- Molecular Wire
 - Current, Conductance vs. Voltage I-V Sweep
- Molecular Transistor
 - Drain Voltage vs. Drain Current Sweep
- Multi-Pin Nanocell
 - Input/Output Characteristics Sweep

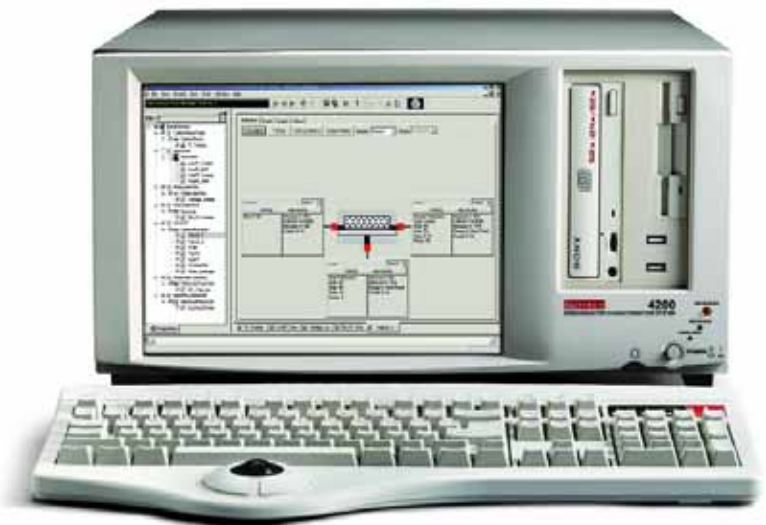

To learn more, see "Improving Low Current Measurements on Nanoelectronic and Molecular Devices," available at www.keithley.com/nano.

Low Current/High Resistance Measurements



Sources and measures the lowest currents in the world

Model 6430 sub-femtoamp remote SourceMeter® instrument

- 0.4fA p-p (4E–16A) noise
- Remote PreAmp can be located at the signal source to minimize cable noise
- $>10^{14}\Omega$ input resistance on voltage measurements
- High speed—up to 2000 readings/second
- Up to 6½-digit resolution
- Fast characterization of components with programmable digital I/O and interfaces

The Model 6430 combines the voltage and current sourcing and measurement functions of Keithley's SourceMeter and Source-Measure Unit (SMU) products with sensitivity, noise, and input resistance specifications superior to electrometers. This unique combination of broad functionality and exceptional measurement integrity is made possible by the Model 6430's Remote PreAmp, which offers a very sensitive bi-directional amplifier with sensitive feedback elements for measuring or sourcing currents at the device being tested. The Model 6430 makes voltage, current and resistance measurements at speeds no electrometer can match. It can read up to 2000 source/measure readings per second into internal memory. Currents can be measured in as little as 5ms on the 100nA range, decreasing to just a few hundred microseconds on the higher ranges.

"The capabilities of the 6430 allow us to measure with a resolution and ease that was previously unavailable in this type of experiment."

*—Heinrich Jaeger, Professor of Physics,
The University of Chicago*



Low Current/High Resistance Measurements



New sources simplify device characterization

Model 6220 DC current source
 Model 6221 AC and DC current source

The Model 6220 DC Current Source and the Model 6221 AC and DC Current Source combine ease of use with exceptionally low current noise. Low current sourcing is critical to applications in test environments ranging from R&D to production, especially in the semiconductor, nanotechnology, and superconductor industries. High sourcing accuracy and built-in control functions make the Models 6220 and 6221 ideal for applications like Hall measurements, resistance measurements using delta mode, pulsed measurements, and differential conductance measurements.

The Model 6221 is the only AC current source on the market and provides better accuracy, consistency, reliability, and robustness than the homemade solutions that were previously necessary. The Model 6221 is also the only commercially available current source waveform generator, which greatly simplifies creating and outputting complex waveforms.

For many applications, the Model 6220 or 6221 can be combined with the Model 2182A low voltage, low resistance nanovoltmeter to create a powerful source and measure system. This combination is easy to use because the two instruments can be treated as a single instrument. Their simple connections eliminate the isolation and noise current problems that plague other options. Working together, the Model 6220/6221 and the Model 2182A are the most complete solution for differential conductance measurements. They are also the fastest, providing 10x the speed and lower noise than other options. The 622x/2182A combination also performs the new three-step delta technique, which eliminates errors due to changing thermoelectric voltages, and provides pulsed resistance and pulsed I-V measurements down to 50µs.



- Low DC current range: 2nA to 100mA (full scale)
- Extremely low current noise: down to 400fA p-p
- RS-232, GPIB, Trigger Link, Digital I/O, and Ethernet (6221 only)
- Reconfigurable triax output simplifies matching the application's guarding requirements
- Model 220 programming compatibility mode
- Versatile example software

6221 only:

- AC current range: 1pA to 100mA
- Very short pulse widths: less than 5µs
- Frequency range: 1mHz to 100kHz
- Arbitrary waveform generator

6220/6221 with 2182A

- Measurement range: 10nΩ to 100MΩ
- Differential conductance mode: 10x faster and lower noise than other solutions
- Delta mode: improves resistance measurements up to 1000x
- Pulse mode (6221 only): coordinated pulse and measurement down to 50µs
- Easy to set up, easy to use (push two buttons)

To read "Low-Level Pulsed Electrical Characterization with the Model 6221/2182A Combination," visit www.keithley.com/nano.

Low Voltage/Low Resistance Measurements

Makes pulsed I-V, resistance, and differential conductance measurements easy

Model 2182A nanovoltmeter

- Measures:
 - Voltages from 10nV to 100V
 - Pulsed I-V down to 50 μ s with Model 6221
 - Differential conductance with Model 6220 or 6221
 - Resistances from 10n Ω to 100M Ω
 - Thermocouple temperatures from -200 $^{\circ}$ C to 1820 $^{\circ}$ C
- Dual channels support measuring voltage, temperature, or the ratio of an unknown resistance to a reference resistor
- Synchronization to line provides 110dB NMRR and minimizes the effect of AC common-mode currents
- In delta mode, coordinates measurements with a reversing current source at up to 24Hz and averages multiple readings for noise down to 1nV



The two-channel Model 2182A Nanovoltmeter is optimized for making stable, low noise, voltage measurements and for characterizing low resistance materials and devices reliably and repeatably. It provides higher measurement speed and significantly better noise performance than alternative low voltage measurement solutions. The Model 2182A replaces Keithley's Model 2182 and offers enhanced capabilities, including pulse capability, lower measurement noise, and faster current reversals. It also offers a simplified delta mode for making resistance measurements in combination with a reversing current source, such as Keithley's Model 6220 or 6221.

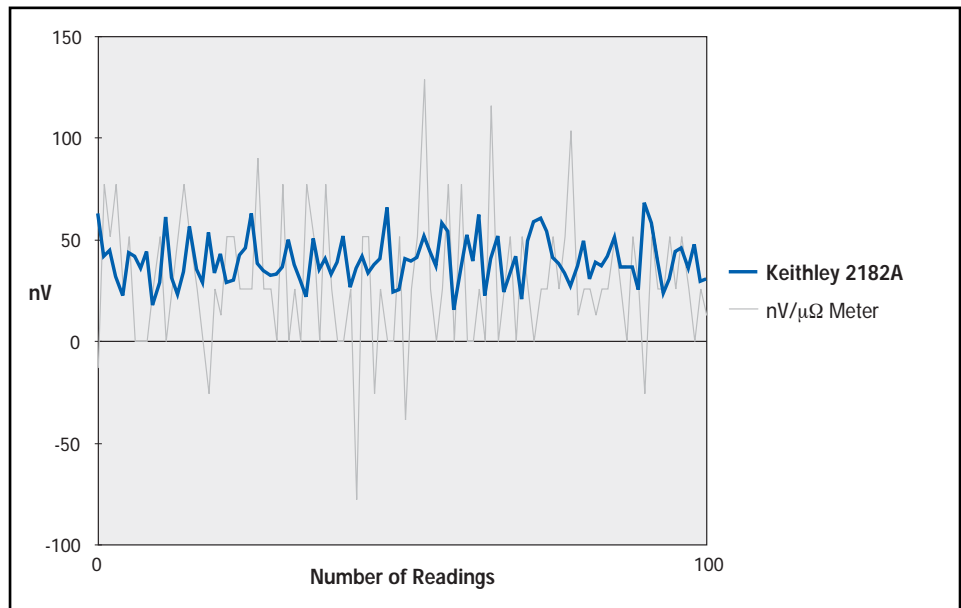

Compare the Model 2182A's DC noise performance with a nanovolt/micro-ohmmeter's. All the data shown was taken at 10 readings per second with a low thermal short applied to the input.

Low Current/High Resistance Measurements

The ultimate tool for measuring low currents and high resistances

Model 6517A electrometer/high resistance system



The Model 6517A Electrometer/High Resistance Meter combines exceptional accuracy and sensitivity with a variety of features that simplify measuring high resistances and the resistivity of insulating materials. With reading rates of up to 125 readings/second, it's also significantly faster than competitive electrometers. The Model 6517A's low current input amplifier has an input bias current of <math>< 3\text{fA}</math> with just 0.75fA p-p (peak-to-peak) noise and <math>< 20\mu\text{V}</math> burden voltage on the lowest range. The input impedance for voltage and resistance measurements is \pm 1\text{kV}</math> voltage source with a sweep capability simplifies leakage, breakdown, and resistance testing, as well as volume ($\Omega\text{-cm}</math>) and surface resistivity ($\Omega/\text{square}</math>) measurements on insulating materials.$$

Several instrument features help ensure the accuracy of high resistance measurement applications. For example, the built-in voltage source simplifies determining the relationship between an insulator's resistivity and the level of source voltage used. It is well suited for capacitor leakage and insulation resistance measurements, tests of the surface insulation resistance of printed circuit boards, voltage coefficient testing of resistors, and diode leakage characterization. A built-in test sequence incorporates a voltage reversal method for measuring very high resistances, especially in materials and devices where the inherent background currents in the sample once made accurate measurements impossible.



Model 6521 and 6522 10-Channel Scanner Cards. Plug either of these cards into the Model 6517A's back panel option slot for multipoint low current testing.

- Measures
 - Currents from 1fA to 20mA
 - Voltages from 10 μV to 200V
 - Resistances up to 10¹⁶ Ω
 - Charges from 10fC to 2 μC
- Simple, DMM-like interface
- <math>< 20\mu\text{V}</math> burden voltage on the lowest current ranges
- 200T $\Omega</math> input impedance$
- <math>< 3\text{fA}</math> bias current
- 0.75fA p-p noise
- Built-in $\pm 1\text{kV}</math> source$



The Model 65 High Resistivity Measurement Package includes the Model 6517A and Model 6524 software, which simplifies operating the 6517A via a computer controller and helps in optimizing the test parameters (delay time, voltage, etc.) for the specific material or device under test. The package also includes the Model 8009 Resistivity Test Fixture and all meter and fixture cables.

Want to learn more? Read "Achieving Accurate and Reliable Resistance Measurements in Low Power and Low Voltage Applications," available at www.keithley.com/nano.

Low Current/High Resistance Measurements

When you just need to measure current

- Cost-effective low current measurement solution
- 20fA lowest noise
- 5½-digit resolution
- <200µV burden voltage
- Up to 1000 readings/second
- Built-in Model 485 emulation mode
- IEEE-488 and RS-232 interfaces
- Analog output
- Driver for LabVIEW™, LabWindows/CVI, Visual Basic, C/C++, and TestPoint™ included
- ExceLINX™ Excel® Add-In included

Model 6485 picoammeter



The 5½-digit Model 6485 picoammeter is a cost-effective instrument that can measure currents from 20fA to 20mA, taking measurements at speeds up to 1000 readings per second. Its 10fA resolution and superior sensitivity make it well suited for characterizing low current phenomena, while its 20mA range lets it measure currents high enough for applications such as measuring 4–20mA sensor loops. Although it employs the latest current measurement technology, it is significantly less expensive than other instruments that perform similar functions, such as optical power meters, competitive picoammeters, or user-designed solutions. With a price that's comparable to a general purpose DMM, the Model 6485 makes picoamp-level measurements affordable for virtually any laboratory or production floor. While DMMs typically employ shunt ammeter circuitry to measure current, the Model 6485 is a feedback picoammeter. This design reduces voltage burden by several orders of magnitude, resulting in a voltage burden of less than 200µV on the lower measurement ranges. The low voltage burden makes the Model 6485 function much more like an ideal ammeter than a DMM, so it can make current measurements with high accuracy, even in circuits with very low source voltages.

Adds voltage sourcing and resistance measurement to the Model 6485's capabilities

Model 6487 picoammeter/voltage source



With eight current measurement ranges and high speed autoranging, the Model 6487 Picoammeter/Voltage Source instrument can measure currents from 20fA to 20mA, take measurements at speeds up to 1000 readings per second, and source voltage from 200µV to 505V. Its 10fA resolution, superior sensitivity, voltage sweeping, and Alternating Voltage resistance measurements make it well suited for characterizing low current devices. Using the latest current measurement technology, it is significantly less expensive than other instruments that perform similar functions, such as optical power meters, tera-ohmmeters, competitive picoammeters, or user-designed solutions. With a price that's comparable to a high end DMM, the Model 6487 makes picoamp-level measurements affordable for virtually any laboratory or production floor.

- 20fA lowest noise
- 5½-digit resolution
- <200µV burden voltage
- Alternating Voltage method ohms measurements
- Automated voltage sweeps for I-V characterization up to 10¹⁵Ω
- Floating measurements up to 500V
- Up to 1000 readings/second
- Built-in Model 486 and 487 emulation mode
- IEEE-488 and RS-232 interfaces
- Digital I/O
- Driver for LabVIEW™, LabWindows™/CVI, Visual Basic®, C/C++, and TestPoint™ included
- ExceLINX™ Excel Add-In included

Other Model 6487 features include:

- Direct resistance measurements using the Source Voltage/Measure Current method
- Alternating Voltage method, which improves resistance measurements on devices with high background current or high noise, and extends the measurable resistance range up to 10¹⁵Ω
- 500V overload protection
- Scaled voltage analog output, which allows the Model 6487 to transmit measurement results to devices like DMMs, data acquisition cards, oscilloscopes, or strip chart recorders
- Display on/off switch for use in research on light-sensitive components





- Combines a precision power supply, true current source, DMM, arbitrary waveform generator, V or I pulse generator with measurement, electronic load, and trigger controller—all in one instrument
- TSP-Link™ master/slave connection seamlessly integrates multiple Series 2600 SourceMeter channels into a system that can be programmed and controlled as a single instrument
- Free Test Script Builder software simplifies creating powerful test scripts for programming custom test functions
- Free LabTracer™ 2.0 software provides curve tracing and fast, easy startup

Scalable solutions for high speed R&D and functional testing

Series 2600 System SourceMeter® multi-channel I-V test solutions

The Series 2600 System SourceMeter instruments provide high speed source-measure capability plus advanced automation features and time-saving software tools, making them ideal solutions for I-V testing of a wide range of devices.

Each System 2600 combines all this functionality in one compact unit: precision power supply, true current source, digital multimeter, arbitrary waveform generator, V or I pulse generator, and electronic load and trigger controller.

Free LabTracer™ 2.0 software makes it simple to configure and control up to eight Series 2600 or 2400 SourceMeter channels for curve tracing or device characterization with a simple GUI for setup, control, data acquisition, and graphing of DUT data. Drop-down menus in the instrument setup window allow configuring any SourceMeter channel for fixed point or sweeping operation. No programming is required.

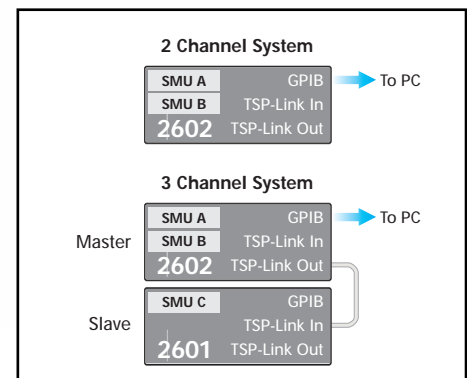

TSP-Link, a high speed system expansion interface, makes it easy to scale the system's channel count to match the application.

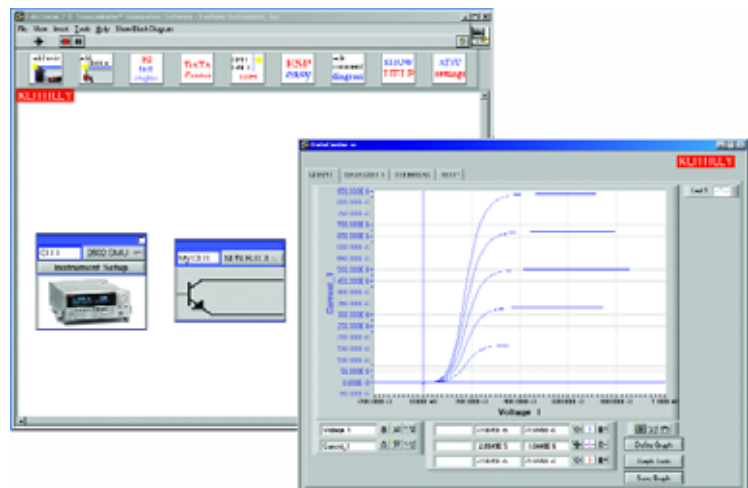

For further reading, download "Nanoscale Device and Material Electrical Measurements," from www.keithley.com/nano.

- Family of products offers wide dynamic range: 10pA to 10A, 1 μ V to 1100V, 20W to 1000W
- 4-quadrant operation
- 0.012% basic accuracy with 5 $\frac{1}{2}$ -digit resolution
- 6-wire Ω measurement with programmable I source and V clamp
- 1700 readings/second at 4 $\frac{1}{2}$ digits via GPIB
- Built-in comparator for fast pass/fail testing
- Optional contact check function
- Digital I/O for fast binning and connection to component handlers
- GPIB, RS-232, and Trigger Link interfaces
- TestPoint and LabVIEW drivers



Widest I-V dynamic range for high speed automated and benchtop testing

Series 2400 SourceMeter® line

The Series 2400 SourceMeter® instrument family is designed specifically for test applications that demand tightly coupled precision voltage and current sourcing and measurement. All SourceMeter models combine a precision, low noise, highly stable DC power supply with readback and a low noise, highly repeatable, high impedance, 5 $\frac{1}{2}$ -digit multimeter. The result is a compact, single-channel, DC parametric tester. In operation, these instruments can act as a V-Source, an I-Source, a V-Meter, an I-Meter, and an ohmmeter. They offer a variety of advantages over systems configured with separate source and measurement instruments. For example, their compact half-rack size conserves precious space

in the test rack or bench. They also minimize the test station development, set-up, and maintenance time required, while lowering the overall cost of system ownership. In addition, SourceMeter instruments simplify the test process itself by eliminating many of the complex synchronization and connection issues associated with using multiple instruments. All SourceMeter instruments are suitable for making a wide range of DC measurements, including resistance at a specified current or voltage, breakdown voltage, leakage current, insulation resistance, and electrical characterization.

Control a wide range of pulse parameters

Series 3400 pulse/pattern generators



Series 3400 Pulse/Pattern Generators are the latest additions to Keithley's growing line of instrumentation with pulse generation functions. They offer users extensive control over a wide variety of pulse parameters, including pulse amplitude, rise time, fall time, width, and duty cycle via the instrument's flexible user interface or over the GPIB and USB interfaces. This operational flexibility makes Series 3400 instruments readily adaptable to the needs of a wide range of users, including nanotechnology researchers, research and education organizations, and semiconductor and RF device design and development departments. Built-in pattern generation capabilities simplify simulating serial data patterns when testing devices to characterize their performance when operated under sub-optimal conditions.

Series 3400 instruments offer users some important performance advantages over some of the best-selling pulse/pattern generators on the market, including:

- Clean transient response
- Simpler user interface
- Less edge-to-edge jitter
- Easier integration into existing test and measurement systems

- Broad-purpose voltage pulse and pattern generation
- Programmable pulse parameters: amplitude, rise time, fall time, pulse width, and duty cycle
- Pulse and burst modes for material and device characterization
- Serial data pattern simulation for functional characterization tasks
- Choice of single- or dual-channel signal outputs
- 1mHz–165MHz frequency output range
- Independently adjustable rise and fall times
- 3ns–1000s pulse width range
- Four operating modes: pulse, burst, pattern, external width
- GPIB and USB interfaces
- 2U full-rack design

Prevent device heating during test with the industry's only pulsed LIV test system

Model 2520 pulsed LIV test system

- Simplifies LIV testing prior to packaging or active temperature control
- Integrated solution for in-process LIV production testing
- Combines high accuracy source and measure capabilities for pulsed and DC testing



The tight synchronization of source and measure capabilities in the Model 2520 ensures high measurement accuracy, even when testing with pulse widths as short as 500ns. It can perform pulsed LIV testing up to 5A and continuous LIV testing up to 1A. Its pulsed testing capability makes it suitable for testing a broad range of nanophotonic devices. The mainframe and remote test head architecture enhances pulsed measurement accuracy.

To explore further, download the Series 3400 data sheet from
www.keithley.com/nano.

Visit our online nano resource to discover what you've been missing

We've compiled all our nanotechnology resources in one convenient location: www.keithley.com/nano. There, you'll discover our growing library of low level measurement white papers, application notes, articles, and other literature. Even if you've visited our site previously, we encourage you to revisit it often because we're constantly developing and posting new materials on this topic. While there, you may want to subscribe to *NanoNews*, our quarterly email newsletter, designed to make it easy to stay up to date on Keithley's latest nanotechnology measurement solutions.



Talk to Keithley

There's a Keithley applications engineer ready with advice on configuring a test system tailored to your low current sourcing or measurement application. Call us toll free at **1-888-KEITHLEY (534-8453)** (US only) or call your local Keithley sales office (listed below) and ask to speak with one of our low level instrumentation specialists.



Visit www.keithley.com/nano to learn how to make measurements suited for nanotechnology applications.

Specifications are subject to change without notice.
All Keithley trademarks and trade names are the property of Keithley Instruments, Inc.
All other trademarks and trade names are the property of their respective companies.

KEITHLEY

A G R E A T E R M E A S U R E O F C O N F I D E N C E

KEITHLEY INSTRUMENTS, INC. ■ 28775 AURORA ROAD ■ CLEVELAND, OHIO 44139-1891 ■ 440-248-0400 ■ Fax: 440-248-6168 ■ 1-888-KEITHLEY ■ www.keithley.com

BELGIUM

Sint-Pieters-Leeuw
Ph: 32-2363-0040
Fax: 32-2363-0064
www.keithley.nl

CHINA

Beijing
Ph: 8610-82255010
Fax: 8610-82255018
www.keithley.com.cn

FINLAND

Espoo
Ph: 358 9 88171661
Fax: 358 9 88171662
www.keithley.com

FRANCE

Saint-Aubin
Ph: 33-1-6453-2020
Fax: 33-1-60-1-77-26
www.keithley.fr

GERMANY

Germering
Ph: 49-89-84-93-070
Fax: 49-89-84-93-0734
www.keithley.de

UNITED KINGDOM

Theale
Ph: 44-118-929-7500
Fax: 44-118-929-7519
www.keithley.co.uk

INDIA

Bangalore
Ph: 91-80-2212-8027
Fax: 91-80-2212-8005
www.keithley.com

ITALY

Milano
Ph: 39-02-553-8421
Fax: 39-02-55 38 42 28
www.keithley.it

JAPAN

Tokyo
Ph: 81-3-5733-7555
Fax: 81-3-5733-7556
www.keithley.jp

KOREA

Seoul
Ph: 82-2-574-7778
Fax: 82-2-574-7838
www.keithley.co.kr

MALAYSIA

Kuala Lumpur
Ph: 60-3-4041-0899
Fax: 60-3-4042-0899
www.keithley.com

NETHERLANDS

Gorinchem
Ph: 31-1-836-35333
Fax: 31-1-836-30821
www.keithley.nl

SINGAPORE

Singapore
Ph: 65-6747-9077
Fax: 65-6747-2991
www.keithley.com.sg

SWEDEN

Solna
Ph: 46-8-509-04-600
Fax: 46-8-655-26-10
www.keithley.com

TAIWAN

Hsinchu
Ph: 886-3-572-9077
Fax: 886-3-572-9031
www.keithley.com.tw